

**ASME B18.5-2008**  
[Revision of ASME B18.5-1990 (R2003)]

# Round Head Bolts (Inch Series)

FINESZ 泛微

苏州泛越工业科技有限公司 整理  
[www.finesz.com](http://www.finesz.com)

**AN AMERICAN NATIONAL STANDARD**



The American Society of  
Mechanical Engineers



**ASME B18.5-2008**

**[Revision of ASME B18.5-1990 (R2003)]**

# **Round Head Bolts (Inch Series)**

FINESZ 泛微

**AN AMERICAN NATIONAL STANDARD**



**The American Society of  
Mechanical Engineers**



Date of Issuance: September 5, 2008

This Standard will be revised when the Society approves the issuance of a new edition. There will be no addenda issued to this edition.

ASME issues written replies to inquiries concerning interpretations of technical aspects of this document. Periodically, certain actions of the ASME B18 Committee may be published as Cases. Cases and interpretations are published on the ASME Web site under the Committee Pages at <http://cstools.asme.org> as they are issued.

ASME is the registered trademark of The American Society of Mechanical Engineers.

This code or standard was developed under procedures accredited as meeting the criteria for American National Standards. The Standards Committee that approved the code or standard was balanced to assure that individuals from competent and concerned interests have had an opportunity to participate. The proposed code or standard was made available for public review and comment that provides an opportunity for additional public input from industry, academia, regulatory agencies, and the public-at-large.

ASME does not “approve,” “rate,” or “endorse” any item, construction, proprietary device, or activity.

ASME does not take any position with respect to the validity of any patent rights asserted in connection with any items mentioned in this document, and does not undertake to insure anyone utilizing a standard against liability for infringement of any applicable letters patent, nor assume any such liability. Users of a code or standard are expressly advised that determination of the validity of any such patent rights, and the risk of infringement of such rights, is entirely their own responsibility.

Participation by federal agency representative(s) or person(s) affiliated with industry is not to be interpreted as government or industry endorsement of this code or standard.

ASME accepts responsibility for only those interpretations of this document issued in accordance with the established ASME procedures and policies, which precludes the issuance of interpretations by individuals.

No part of this document may be reproduced in any form,  
in an electronic retrieval system or otherwise,  
without the prior written permission of the publisher.

The American Society of Mechanical Engineers  
Three Park Avenue, New York, NY 10016-5990

Copyright © 2008 by  
THE AMERICAN SOCIETY OF MECHANICAL ENGINEERS  
All rights reserved  
Printed in U.S.A.

# CONTENTS

Foreword . . . . .	iv
Committee Roster . . . . .	v
Correspondence With the B18 Committee . . . . .	vi
<b>1 Introductory Notes . . . . .</b>	<b>1</b>
<b>2 General Data. . . . .</b>	<b>2</b>
<b>Tables</b>	
1 Dimensions of Round Head Bolts . . . . .	4
2 Dimensions of Round Head Square Neck Bolts . . . . .	5
3 Dimensions of Round Head Short Square Neck Bolts . . . . .	6
4 Dimensions of Round Head Ribbed Neck Bolts . . . . .	7
5 Dimensions of Round Head Fin Neck Bolts . . . . .	8
6 Dimensions of Step Bolts . . . . .	9
7 Dimensions of Countersunk Bolts and Slotted Countersunk Bolts . . . . .	10
8 Dimensions of 114-deg Countersunk Square Neck Bolts . . . . .	11
9 Dimensions of Flat Countersunk Head Elevator Bolts . . . . .	12
10 Dimensions of T-Head Bolts . . . . .	13



# FOREWORD

American National Standards Committee B18 for the standardization of bolts, screws, nuts, rivets, and similar fasteners was originated in March 1922 as Sectional Committee B18, under the aegis of the American Engineering Standards Committee [later the American Standards Association, the United States of America Standards Institute, and as of October 6, 1969, the American National Standards Institute, Inc. (ANSI)], with the Society of Automotive Engineers and the American Society of Mechanical Engineers as joint sponsors. Subcommittee 5 was subsequently established and charged with the responsibility for technical content of standards covering round unslotted head bolts.

The initial proposal completed by the Subcommittee in February of 1923 consisted of standards covering head dimensions for carriage, step, and round head machine bolts. Circulation of the original draft and numerous revisions thereto culminated in a document that was issued as a Tentative American Standard on February 20, 1928.

In 1934, Subcommittee 5 initiated work on a revision of the standard to bring it into line with altered consumer requirements and refinements in manufacturing technology. A proposal containing dimensional changes and additional data was duly approved and issued as a revision in 1939.

Early in 1947, Subcommittee 5 commenced to conduct an extensive review of the existing document and to expand it into a complete product standard. Over the ensuing three years, the Subcommittee developed a proposal incorporating the adoption of a shorter depth of square neck and the addition of coverage for commonly used elevator bolts and T-head bolts plus a round head short square neck bolt used extensively by the farm equipment industry in thin metals. Subsequent to acceptance by the Subcommittee, the B18 Committee, and sponsor organizations, the proposal was submitted to the American Standards Association for approval and designation as an American National Standard. This was granted on March 12, 1952.

In 1966, the Subcommittee, recognizing the need for updating the standard, undertook development of a revision. Numerous meetings and work sessions resulted in Subcommittee acceptance of a draft incorporating changes to clarify intent and overcome inconsistencies in specifications and format with related documents. Included were the redimensioning of countersunk type heads, the adoption of new tolerances on bolt length, the addition of straightness requirements, and the elimination of coverage for ribbed head type elevator bolts. Following letter ballot approval by the B18 Standards Committee and the sponsor organizations, the revision was submitted to the American National Standards Institute and was designated an American National Standard on January 20, 1971.

In 1977, the Subcommittee again recognized the need for a revision. Following letter ballot approval by the B18 Standards Committee, the revision was approved by the Secretariat and ANSI on September 8, 1978.

The B18 Committee began a revision in 1984 to upgrade the standard to include information on identification symbols and to add quality assurance provisions.

In December 1986, the ASME B18 Committee agreed to combine Subcommittee 5 into Subcommittee 2, since the product lines each Subcommittee addresses are quite similar.

The B18 Committee further agreed the designation of the Subcommittee 2 and 5 documents not be changed, since this would adversely affect current reference to these Standards.

Following approval by the B18 Committee, the previous edition was approved by the American National Standards Institute on December 27, 1990.

This edition was balloted and approved by the B18 Standards Committee and B18 Subcommittee 2 on December 27, 2007.

This revision, ASME B18.5-2008, was approved by the American National Standards Institute on March 27, 2008.

# ASME B18 COMMITTEE

## Standardization of Bolts, Nuts, Rivets, Screws, Washers, and Similar Fasteners

(The following is the roster of the Committee at the time of approval of this Standard.)

### STANDARDS COMMITTEE OFFICERS

**D. A. Clever**, *Chair*  
**R. D. Strong**, *Vice Chair*  
**S. W. Vass**, *Vice Chair*  
**R. L. Crane**, *Secretary*

### STANDARDS COMMITTEE PERSONNEL

<b>V. Cartina</b> , Continental-Aero	<b>W. H. Kopke</b> , ITW Shakeproof Assembly Components
<b>D. A. Clever</b> , Deere & Co.	<b>J. G. Langenstein</b> , <i>Honorary Member</i> , Consultant
<b>A. P. Cockman</b> , Ford Motor Co.	<b>W. J. Lutkus</b> , Heli-Coil Emhart
<b>R. L. Crane</b> , The American Society of Mechanical Engineers	<b>D. McCrindle</b> , Canadian Fasteners Institute
<b>A. C. DiCola</b> , Wrought Washer Co.	<b>M. D. Prasad</b> , <i>Contributing Member</i> , General Motors Corp.
<b>B. A. Dusina</b> , Federal Screw Works	<b>S. Savoji</b> , ITW Medalist
<b>J. S. Foote</b> , <i>Contributing Member</i> , Trade Association Management, Inc.	<b>W. R. Schevey</b> , <i>Contributing Member</i> , BGM Fastener Co., Inc.
<b>D. S. George</b> , ND Industries	<b>W. R. Stevens</b> , Ramco
<b>J. Greenslade</b> , Industrial Fasteners Institute	<b>R. D. Strong</b> , General Motors Corp.
<b>J. J. Grey</b> , <i>Contributing Member</i> , Fastener Consulting Services, Inc.	<b>S. W. Vass</b> , Consultant
<b>B. Hasiuk</b> , <i>Contributing Member</i> , Defense Industrial Supply Center Philadelphia	<b>C. B. Wackrow</b> , <i>Contributing Member</i> , MNP Corp.
<b>A. Herskovitz</b> , Consultant	<b>W. K. Wilcox</b> , Consultant
<b>J. Jennings</b> , <i>Contributing Member</i> , Naval Surface Warfare Center	<b>C. B. Williamson</b> , Fastenal Co.
<b>J. F. Koehl</b> , <i>Contributing Member</i> , Spirol International Corp.	<b>C. J. Wilson</b> , Consultant
	<b>R. B. Wright</b> , <i>Contributing Member</i> , Wright Tool Co.
	<b>J. G. Zeratsky</b> , National Rivet and Manufacturing Co.

### SUBCOMMITTEE 2 — EXTERNALLY DRIVEN FASTENERS

<b>J. Greenslade</b> , <i>Chair</i> , Industrial Fasteners Institute	<b>J. Hubbard</b> , Rockford Fastener, Inc.
<b>C. B. Williamson</b> , <i>Vice Chair</i> , Fastenal Co.	<b>J. Jennings</b> , <i>Contributing Member</i> , Naval Surface Warfare Center
<b>R. L. Crane</b> , <i>Secretary</i> , The American Society of Mechanical Engineers	<b>W. H. King</b> , Porteous Fastener Co.
<b>V. Cartina</b> , Continental-Aero	<b>J. F. McCarrick</b> , Defense Supply Center Philadelphia
<b>D. A. Clever</b> , Deere & Co.	<b>D. McCrindle</b> , Canadian Fasteners Institute
<b>A. P. Cockman</b> , Ford Motor Co.	<b>R. B. Meade</b> , Atroma Material Testing Laboratories, Inc.
<b>P. J. DeChant</b> , Barnes Distribution	<b>S. Savoji</b> , ITW Medalist
<b>C. A. Dugal</b> , TSP	<b>G. M. Simpson</b> , Semblex Corp.
<b>B. A. Dusina</b> , Federal Screw Works	<b>Q. M. Smith III</b> , Dana Corp.
<b>M. A. Elmi</b> , Caterpillar, Inc.	<b>W. R. Stevens</b> , Ramco
<b>J. S. Foote</b> , Trade Association Management, Inc.	<b>R. D. Strong</b> , General Motors Corp.
<b>D. S. George</b> , ND Industries	<b>S. W. Vass</b> , Consultant
<b>A. Herskovitz</b> , Consultant	<b>C. B. Wackrow</b> , MNP Corp.
<b>M. W. Holubecki</b> , Electric Boat Corp.	<b>W. K. Wilcox</b> , Consultant
	<b>C. J. Wilson</b> , Consultant

## CORRESPONDENCE WITH THE B18 COMMITTEE

**General.** ASME Standards are developed and maintained with the intent to represent the consensus of concerned interests. As such, users of this Standard may interact with the Committee by requesting interpretations, proposing revisions, and attending Committee meetings. Correspondence should be addressed to:

Secretary, B18 Standards Committee  
The American Society of Mechanical Engineers  
Three Park Avenue  
New York, NY 10016-5990

**Proposing Revisions.** Revisions are made periodically to the Standard to incorporate changes that appear necessary or desirable, as demonstrated by the experience gained from the application of the Standard. Approved revisions will be published periodically.

The Committee welcomes proposals for revisions to this Standard. Such proposals should be as specific as possible, citing the paragraph number(s), the proposed wording, and a detailed description of the reasons for the proposal, including any pertinent documentation.

**Proposing a Case.** Cases may be issued for the purpose of providing alternative rules when justified, to permit early implementation of an approved revision when the need is urgent, or to provide rules not covered by existing provisions. Cases are effective immediately upon ASME approval and shall be posted on the ASME Committee Web page.

Requests for Cases shall provide a Statement of Need and Background Information. The request should identify the standard, the paragraph, figure or table number(s), and be written as a Question and Reply in the same format as existing Cases. Requests for Cases should also indicate the applicable edition(s) of the standard to which the proposed Case applies.

**Interpretations.** Upon request, the B18 Standards Committee will render an interpretation of any requirement of the Standard. Interpretations can only be rendered in response to a written request sent to the Secretary of the B18 Standards Committee.

The request for an interpretation should be clear and unambiguous. It is further recommended that the inquirer submit his/her request in the following format:

Subject: Cite the applicable paragraph number(s) and the topic of the inquiry.  
Edition: Cite the applicable edition of the Standard for which the interpretation is being requested.  
Question: Phrase the question as a request for an interpretation of a specific requirement suitable for general understanding and use, not as a request for an approval of a proprietary design or situation. The inquirer may also include any plans or drawings that are necessary to explain the question; however, they should not contain proprietary names or information.

# ROUND HEAD BOLTS (INCH SERIES)

## 1 INTRODUCTORY NOTES

### 1.1 Scope

**1.1.1** This Standard covers the complete general and dimensional data for the various types of inch series bolts generally classified as round head bolts and recognized as American National Standard.

**1.1.2** The inclusion of dimensional data in this Standard is not intended to imply that all of the products described are stock production sizes. Consumers should consult with manufacturers concerning availability of products.

### 1.2 Bolt Types

The bolt types covered by this Standard are enumerated and described in paras. 1.2.1 through 1.2.10.

**1.2.1 Round Head Bolt (Formerly Designated Button Head Bolt).** The round head bolt shall have a circular head with a low rounded top surface and a flat bearing surface. Dimensions are given in Table 1.

**1.2.2 Round Head Square Neck Bolt (Formerly Designated Round Head Carriage Bolt).** The round head square neck bolt shall have a circular head with a low rounded top surface and a flat bearing surface, and an integrally formed square neck under the head. Dimensions are given in Table 2.

**1.2.3 Round Head Short Square Neck Bolt.** The round head short square neck bolt shall have a circular head with a low rounded top surface and a flat bearing surface, and an integrally formed short length square neck under the head. Dimensions are given in Table 3.

**1.2.4 Round Head Ribbed Neck Bolt (Formerly Designated Ribbed Neck Carriage Bolt).** The round head ribbed neck bolt shall have a circular head with a low rounded top surface and a flat bearing surface, and a ribbed or splined neck formed on the shank below the head. Dimensions are given in Table 4.

**1.2.5 Round Head Fin Neck Bolt (Formerly Designated Fin Neck Carriage Bolt).** The round head fin neck bolt shall have a circular head with a low rounded top surface and a flat bearing surface, and two diametrically opposite integrally formed fins at the junction of head with shank. Dimensions are given in Table 5.

**1.2.6 Step Bolt.** The step bolt shall have a large circular head with a low rounded top surface and a flat

bearing surface, and an integrally formed square neck under the head. Dimensions are given in Table 6.

**1.2.7 Countersunk Bolt.** The countersunk bolt shall have a circular head with a flat top surface and a conical bearing surface having a head angle of approximately 80 deg. Countersunk bolts are available with and without a slot in the head, as specified by the purchaser. Dimensions are given in Table 7.

**1.2.8 114-deg Countersunk Square Neck Bolt (Formerly Designated Countersunk Carriage Bolt).** The 114-deg countersunk square neck bolt shall have a circular head with a flat top surface and a conical bearing surface having a head angle of approximately 114 deg, and an integrally formed square neck under the head. Dimensions are given in Table 8.

**1.2.9 Flat Countersunk Head Elevator Bolt.** The flat countersunk head elevator bolt shall have a large circular head with a flat top surface and a shallow conical bearing surface, and an integrally formed square neck under the head. Dimensions are given in Table 9.

**1.2.10 T-Head Bolt.** The T-head bolt shall have a rectangular head with a rounded top surface and a flat bearing surface. Dimensions are given in Table 10.

### 1.3 Terminology

For definitions of terms relating to fasteners or component features thereof used in this Standard, refer to ASME B18.12.

### 1.4 Dimensions

All dimensions in this Standard are given in inches, unless otherwise stated.

### 1.5 Designation

Round head bolts are designated by the following data, preferably in the sequence shown:

- (a) product name and designation of the standard
- (b) nominal diameter, threads per inch, and nominal length
- (c) material grade or identification, and protective coating, if required

#### EXAMPLES:

- (1) Round head short square neck bolt ASME B18.5,  $\frac{3}{8}$ -16  $\times$  3, steel ASTM A 307, Grade A, zinc plated ASTM F 1941, Fe/Zn 3A.
- (2) Step bolt ASME B18.5,  $\frac{1}{2}$ -13  $\times$  4, stainless steel, ASTM F 593 alloy group 1.



## 1.6 Referenced Standards

The following is a list of publications referenced in this Standard. Unless otherwise specified, the standards referenced shall be the most recent issue at the time of order placement.

ANSI B18.6.2, Slotted Head Cap Screws, Square Head Set Screws, and Slotted Headless Set Screws

ASME B1.1, Unified Inch Screw Threads (UN and UNR Thread Form)

ASME B1.3M, Screw Thread Gaging Systems for Dimensional Acceptability — Inch and Metric Screw Threads (UN, UNR, UNJ, M, and MJ)

ASME B18.2.9, Straightness Gage and Gaging for Bolts and Screws

ASME B18.12, Glossary of Terms for Mechanical Fasteners

ASME B18.18.1, Inspection and Quality Assurance for General Purpose Fasteners

ASME B18.18.2, Inspection and Quality Assurance for High-Volume Machine Assembly Fasteners

Publisher: The American Society of Mechanical Engineers (ASME), Three Park Avenue, New York, NY 10016-5990; Order Department: 22 Law Drive, P.O. Box 2300, Fairfield, NJ 07007-2300

ASTM A 307, Carbon Steel Bolts and Studs, 60,000 PSI Tensile Strength

ASTM F 468, Nonferrous Bolts, Hex Cap Screws, and Studs for General Use

ASTM F 593, Stainless Steel Bolts, Hex Cap Screws, and Studs

ASTM F 788/F 788M, Surface Discontinuities of Bolts, Screws, and Studs, Inch and Metric Series

Publisher: ASTM International (ASTM), 100 Barr Harbor Drive, P.O. Box C700, West Conshohocken, PA 19428-2959

SAE J429, Mechanical and Material Requirements for Externally Threaded Fasteners

Publisher: Society of Automotive Engineers (SAE), 400 Commonwealth Drive, Warrendale, PA 15096-0001

## 2 GENERAL DATA

### 2.1 Heads

**2.1.1 Height of Head.** The height of head shall be measured, parallel to the axis of bolt, from the top of the head to the bearing surface for flat bearing surface type heads, and from the top of the head to the point of intersection of the conical bearing surface of the head with the flat of square neck or the body diameter, whichever is applicable for countersunk heads.

**2.1.2 Head Periphery.** Because the heads on these products normally are not machined or trimmed, the circumference may be somewhat irregular and the edge may be rounded or flat.

**2.1.3 Underhead Fillets.** All bolts having flat bearing surface type heads shall have a definite fillet at the junction of head and shank. The minimum radius of fillet shall be equal to one-half of the maximum values specified in the respective dimensional tables. The radius of fillet shall not exceed the values specified in the respective dimensional tables except for bolts produced from nonferrous and corrosion-resistant materials, on which maximum fillets shall be subject to agreement between manufacturer and purchaser.

### 2.2 Square Neck

**2.2.1 Depth of Square.** The depth of square shall be measured, parallel to the axis of bolt at the midpoint of the flats of square, from the bottom of square to the bearing surface for bolts having flat bearing surface type heads, and to the intersection of flats of square with the conical bearing surface for bolts having countersunk heads.

**2.2.2 Corners of Square.** The corners of square neck may be rounded to the extent specified in the respective dimensional tables and need not be filled out for the total depth of square.

### 2.3 Body Diameter

**2.3.1 Full Diameter Body.** Unless otherwise specified, all bolts covered by this Standard, except round head square neck bolts and round head short square neck bolts, will be furnished with full diameter body of limits given in the dimensional tables.

**2.3.2 Round Head Square Neck and Round Head Short Square Neck Bolt Diameter Body.** Unless otherwise specified, round head square neck bolts and round head short square neck bolts shall be furnished with a body diameter having a maximum limit equal to that of the full diameter body and a minimum limit equal to the minimum pitch diameter of the thread as given in the dimensional tables.

**2.3.3 Swell or Fin.** A swell or fin under the head or under corners of square neck shall be permissible, provided it does not affect serviceability, nor exceed the basic bolt diameter by more than the following:

- (a) 0.030 in. for sizes up to and including  $\frac{1}{2}$  in.
- (b) 0.050 in. for sizes over  $\frac{1}{2}$  in. to  $\frac{3}{4}$  in., inclusive
- (c) 0.063 in. for sizes over  $\frac{3}{4}$  in. to  $1\frac{1}{4}$  in., inclusive
- (d) 0.093 in. for sizes over  $1\frac{1}{4}$  in.

### 2.4 Length

**2.4.1 Measurement.** The length of the bolt shall be measured, parallel to the axis of the bolt, from the end

of the bolt to the bearing surface for bolts having flat bearing surface type heads, and to the top of the head for bolts having countersunk-type heads.

**2.4.2 Tolerance on Length.** The tolerance on length of bolts shall be as tabulated below.

Nominal Bolt Size	No. 10 Through	$\frac{7}{16}$ and	$\frac{9}{16}$ Through	$\frac{7}{8}$ and	$\frac{1}{8}$ Through
	$\frac{3}{8}$	$\frac{1}{2}$	$\frac{3}{4}$	1	$1\frac{1}{2}$
Nominal Bolt Length	Tolerance on Length				
Up to 1 in., incl.	+0.02	+0.02	+0.02	...	...
	-0.03	-0.03	-0.03	...	...
Over 1 in. to $2\frac{1}{2}$ in., incl.	+0.02	+0.04	+0.06	+0.08	+0.12
	-0.04	-0.05	-0.08	-0.10	-0.12
Over $2\frac{1}{2}$ in. to 4 in., incl.	+0.04	+0.06	+0.08	+0.10	+0.16
	-0.06	-0.08	-0.10	-0.14	-0.16
Over 4 in. to 6 in., incl.	+0.06	+0.08	+0.10	+0.12	+0.18
	-0.10	-0.10	-0.10	-0.16	-0.18
Over 6 in.	+0.10	+0.12	+0.14	+0.16	+0.22
	-0.18	-0.18	-0.18	-0.20	-0.22

**2.4.3 Straightness.** The length of any permissible swell on the body under the head or neck of bolts shall be excluded from checks for shank straightness. A suggested gage and a gaging procedure for checking straightness are shown in ASME B18.2.9.

## 2.5 Threads

Uncoated threads shall be Unified coarse (UNC or UNRC Series), Class 2A, in accordance with ASME B1.1. Coated threads shall be accepted based on 3A high limits and 2A low limits.

Unless otherwise specified, gaging for screw thread dimensional acceptability shall be in accordance with Gaging System 21 as specified in ASME B1.3M.

## 2.6 Length of Thread

**2.6.1 Measurement.** The length of thread shall be measured, parallel to the axis of the bolt, from the end of the bolt to the last complete (full form) thread.

**2.6.2 Minimum Thread Length.** The minimum length of thread shall be equal to twice the basic bolt diameter plus 0.25 in. for nominal bolt lengths of 6 in. or shorter, and twice the basic bolt diameter plus 0.50 in. for longer nominal lengths.

Bolts of nominal lengths too short to accommodate the minimum thread lengths shall be threaded for full length. The length from the head or neck to the first complete (full form) thread shall not exceed the length of  $2\frac{1}{2}$  threads for sizes up to and including 1 in., and  $3\frac{1}{2}$  threads for sizes over 1 in.

## 2.7 Points

Bolts need not be pointed.

## 2.8 Materials and Mechanical Properties

**2.8.1 Steel.** Unless otherwise specified, chemical and mechanical properties of steel bolts, except step bolts and elevator bolts, shall conform to Grade A of ASTM A 307, and shall be stress relieved as required by the Standard. Due to peculiarities of the head configurations, steel step bolts and elevator bolts are considered conforming if the tensile strength in pounds is equal to or greater than the values indicated in the applicable material standard.

**2.8.2 Other Materials.** Nonferrous materials are covered in ASTM F 468. Corrosion-resistant steels are covered in ASTM F 593.

## 2.9 Identification Symbols

**2.9.1 Grade Symbols.** Each of the products included in this Standard shall be marked in accordance with the requirements of the applicable specification for its chemistry and mechanical properties.

**2.9.2 Source Symbols.** Each of the products included in this Standard shall be marked to identify the source accepting responsibility for the conformance of the bolt to this and other applicable specifications.

## 2.10 Finish

Unless otherwise specified, round head bolts shall be supplied with natural (as processed) finish, unplated or uncoated.

## 2.11 Workmanship

Bolts shall be free from surface imperfections such as burrs, seams, laps, loose scale, and other surface irregularities that could affect serviceability.

When engineering requirements of the application require control of surface discontinuities, the purchaser shall specify conformance to ASTM F 788/F 788M in the original inquiry and purchase order.

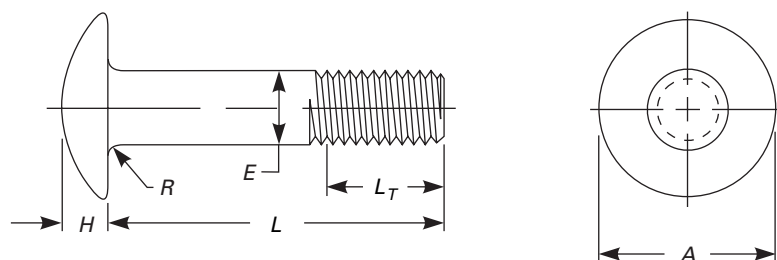
**Table 1 Dimensions of Round Head Bolts**

Nominal Size or Basic Bolt Diameter [Note (1)]		Body Diameter, $E$		Head Diameter, $A$		Head Height, $H$		Maximum Fillet Radius, $R$ [Note (2)]
		Max.	Min.	Max.	Min.	Max.	Min.	
No. 10	0.1900	0.199	0.182	0.469	0.438	0.114	0.094	0.031
$\frac{1}{4}$	0.2500	0.260	0.237	0.594	0.563	0.145	0.125	0.031
$\frac{5}{16}$	0.3125	0.324	0.298	0.719	0.688	0.176	0.156	0.031
$\frac{3}{8}$	0.3750	0.388	0.360	0.844	0.782	0.208	0.188	0.031
$\frac{7}{16}$	0.4375	0.452	0.421	0.969	0.907	0.239	0.219	0.031
$\frac{1}{2}$	0.5000	0.515	0.483	1.094	1.032	0.270	0.250	0.031
$\frac{5}{8}$	0.6250	0.642	0.605	1.344	1.219	0.344	0.313	0.062
$\frac{3}{4}$	0.7500	0.768	0.729	1.594	1.469	0.406	0.375	0.062
$\frac{7}{8}$	0.8750	0.895	0.852	1.844	1.719	0.469	0.438	0.062
1	1.0000	1.022	0.976	2.094	1.969	0.531	0.500	0.062

GENERAL NOTE: For additional requirements, refer to section 2, General Data.

NOTES:

- (1) Where specifying nominal size in decimals, zeros preceding decimal and in the fourth decimal place shall be omitted.
- (2) The minimum radius is one half of the value shown.

## 2.12 Dimensional Conformance

(a) Unless otherwise specified, the following designated characteristics shall be inspected to the inspection levels shown according to ASME B18.18.2, and shall be within specified limits.

Characteristic	Inspection Level
Thread acceptability	C
Length	C
Square neck, rib, or fin length	C
Straightness	C

(b) If a documented, verifiable, statistically based in-process inspection system is used by the fastener manufacturer, inspections may be conducted at any point after which that characteristic will not be altered. Inspection sample sizes and reporting shall be in accordance with recognized quality systems such as ASME, ASTM, and ISO.

(c) For nondesignated characteristics, the provisions of ASME B18.18.1 shall apply.

**Table 2 Dimensions of Round Head Square Neck Bolts**

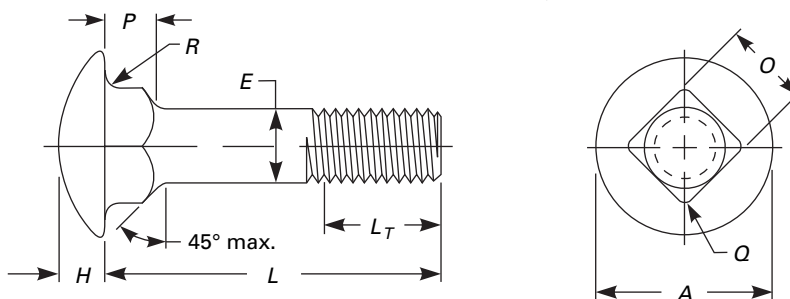

Nominal Size or Basic Bolt Diameter [Note (1)]	Body Diameter, <i>E</i>		Head Diameter, <i>A</i>		Head Height, <i>H</i>		Square Width, <i>O</i>		Square Depth, <i>P</i>		Maximum Corner Radius on Square, <i>Q</i>	Maximum Fillet Radius, <i>R</i> [Note (2)]	
	Max.	Min.	Max.	Min.	Max.	Min.	Max.	Min.	Max.	Min.			
No. 10	0.1900	0.199	0.159	0.469	0.436	0.114	0.094	0.199	0.185	0.125	0.094	0.031	0.031
$\frac{1}{4}$	0.2500	0.260	0.213	0.594	0.563	0.145	0.125	0.260	0.245	0.156	0.125	0.031	0.031
$\frac{5}{16}$	0.3125	0.324	0.272	0.719	0.688	0.176	0.156	0.324	0.307	0.187	0.156	0.031	0.031
$\frac{3}{8}$	0.3750	0.388	0.329	0.844	0.782	0.208	0.188	0.388	0.368	0.219	0.188	0.047	0.031
$\frac{7}{16}$	0.4375	0.452	0.385	0.969	0.907	0.239	0.219	0.452	0.431	0.250	0.219	0.047	0.031
$\frac{1}{2}$	0.5000	0.515	0.444	1.094	1.032	0.270	0.250	0.515	0.492	0.281	0.250	0.047	0.031
$\frac{5}{8}$	0.6250	0.642	0.559	1.344	1.219	0.344	0.313	0.642	0.616	0.344	0.313	0.078	0.062
$\frac{3}{4}$	0.7500	0.768	0.678	1.594	1.469	0.406	0.375	0.768	0.741	0.406	0.375	0.078	0.062
$\frac{7}{8}$	0.8750	0.895	0.795	1.844	1.719	0.459	0.438	0.895	0.865	0.469	0.438	0.094	0.062
1	1.0000	1.022	0.91	2.094	1.969	0.531	0.500	1.022	0.990	0.531	0.500	0.094	0.062

GENERAL NOTE: For additional requirements, refer to section 2, General Data.

NOTES:

- (1) Where specifying nominal size in decimals, zeros preceding decimal and in the fourth decimal place shall be omitted.
- (2) The minimum radius is one half of the value shown.

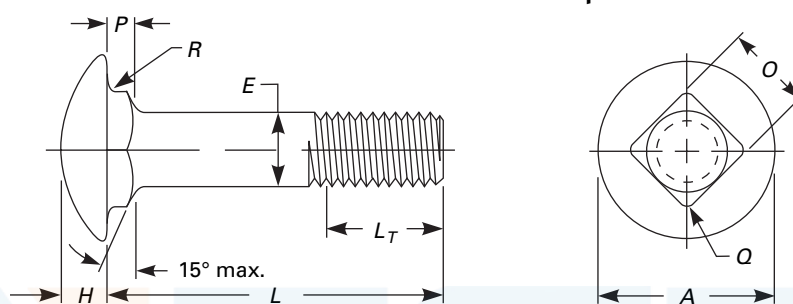
**Table 3 Dimensions of Round Head Short Square Neck Bolts**

Nominal Size or Basic Bolt Diameter [Note (1)]	Body Diameter, <i>E</i>		Head Diameter, <i>A</i>		Head Height, <i>H</i>		Square Width, <i>O</i>		Square Depth, <i>P</i>		Maximum Corner Radius on Square, <i>Q</i>	Maximum Fillet Radius, <i>R</i> [Note (2)]	
	Max.	Min.	Max.	Min.	Max.	Min.	Max.	Min.	Max.	Min.			
$\frac{1}{4}$	0.2500	0.260	0.213	0.594	0.563	0.145	0.125	0.260	0.245	0.124	0.093	0.031	0.031
$\frac{5}{16}$	0.3125	0.324	0.272	0.719	0.688	0.176	0.156	0.324	0.307	0.124	0.093	0.031	0.031
$\frac{3}{8}$	0.3750	0.388	0.329	0.844	0.782	0.208	0.188	0.388	0.368	0.156	0.125	0.047	0.031
$\frac{7}{16}$	0.4375	0.452	0.385	0.969	0.907	0.239	0.219	0.452	0.431	0.156	0.125	0.047	0.031
$\frac{1}{2}$	0.5000	0.515	0.444	1.094	1.032	0.270	0.250	0.515	0.492	0.156	0.125	0.047	0.031
$\frac{5}{8}$	0.6250	0.642	0.559	1.344	1.219	0.344	0.313	0.642	0.616	0.218	0.187	0.078	0.062
$\frac{3}{4}$	0.7500	0.768	0.678	1.594	1.469	0.406	0.375	0.768	0.741	0.218	0.187	0.078	0.062

GENERAL NOTE: For additional requirements, refer to section 2, General Data.

NOTES:

- (1) Where specifying nominal size in decimals, zeros preceding decimal and in the fourth decimal place shall be omitted.
- (2) The minimum radius is one half of the value shown.

**Table 4 Dimensions of Round Head Ribbed Neck Bolts**

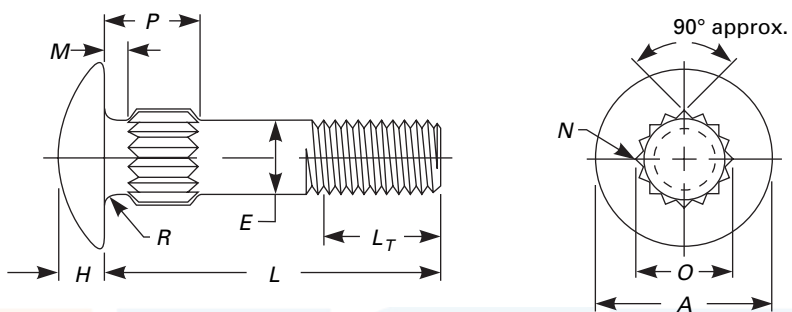

Nominal Size or Basic Bolt Diameter [Note (1)]	Body Diameter, <i>E</i>		Head Diameter, <i>A</i>		Head Height, <i>H</i>		Maximum Head-to-Rib Length, <i>M</i>		Number of Ribs, <i>N</i> Approx.	Minimum Diameter Over Ribs, <i>O</i>	Length of Depth Over Ribs, <i>P</i>			Maximum Fillet Radius, <i>R</i> [Note (2)]	
	Max.	Min.	Max.	Min.	Max.	Min.	≤ 7/8 in.	1 in. and 1 1/8 in.			≥ 1 1/4 in.				
							±0.031	±0.031			±0.031				
No. 10	0.1900	0.199	0.182	0.469	0.438	0.114	0.094	0.062	0.094	9	0.210	0.250	0.407	0.594	0.031
1/4	0.2500	0.260	0.237	0.594	0.563	0.145	0.125	0.062	0.094	10	0.274	0.250	0.407	0.594	0.031
5/16	0.3125	0.324	0.298	0.719	0.688	0.176	0.156	0.062	0.094	12	0.340	0.250	0.407	0.594	0.031
3/8	0.3750	0.388	0.360	0.844	0.782	0.208	0.188	0.062	0.094	12	0.405	0.250	0.407	0.594	0.031
7/16	0.4375	0.452	0.421	0.969	0.907	0.239	0.219	0.062	0.094	14	0.470	0.250	0.407	0.594	0.031
1/2	0.5000	0.515	0.483	1.094	1.032	0.270	0.250	0.062	0.094	16	0.534	0.250	0.407	0.594	0.031
5/8	0.6250	0.642	0.605	1.344	1.219	0.344	0.313	0.125	0.125	19	0.660	0.313	0.438	0.625	0.062
3/4	0.7500	0.768	0.729	1.594	1.469	0.406	0.375	0.125	0.125	22	0.785	0.313	0.438	0.625	0.062

GENERAL NOTE: For additional requirements, refer to section 2, General Data.

NOTES:

- (1) Where specifying nominal size in decimals, zeros preceding decimal and in the fourth decimal place shall be omitted.
- (2) The minimum radius is one half of the value shown.

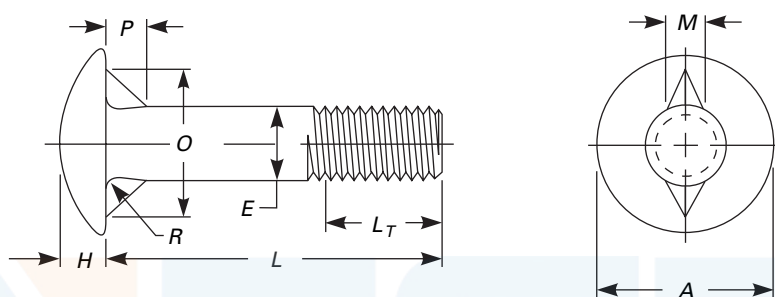
**Table 5 Dimensions of Round Head Fin Neck Bolts**

Nominal Size or Basic Bolt Diameter [Note (1)]	Body Diameter, <i>E</i>		Head Diameter, <i>A</i>		Head Height, <i>H</i>		Fin Thickness, <i>M</i>		Distance Across Fins, <i>O</i>		Fin Depth, <i>P</i>		Maximum Fillet Radius, <i>R</i> [Note (2)]	
	Max.	Min.	Max.	Min.	Max.	Min.	Max.	Min.	Max.	Min.	Max.	Min.		
No. 10	0.1900	0.199	0.182	0.469	0.438	0.114	0.094	0.098	0.078	0.395	0.375	0.088	0.076	0.031
1/4	0.2500	0.260	0.237	0.594	0.563	0.145	0.125	0.114	0.094	0.458	0.438	0.104	0.094	0.031
5/16	0.3125	0.324	0.298	0.719	0.688	0.176	0.156	0.145	0.125	0.551	0.531	0.135	0.125	0.031
3/8	0.3750	0.388	0.360	0.844	0.782	0.208	0.188	0.161	0.141	0.645	0.625	0.151	0.141	0.031
7/16	0.4375	0.452	0.421	0.969	0.907	0.239	0.219	0.192	0.172	0.739	0.719	0.182	0.172	0.031
1/2	0.5000	0.515	0.483	1.094	1.032	0.270	0.250	0.208	0.188	0.833	0.813	0.198	0.188	0.031

GENERAL NOTE: For additional requirements, refer to section 2, General Data.

NOTES:

- (1) Where specifying nominal size in decimals, zeros preceding decimal and in the fourth decimal place shall be omitted.
- (2) The minimum radius is one half of the value shown.

**Table 6 Dimensions of Step Bolts**

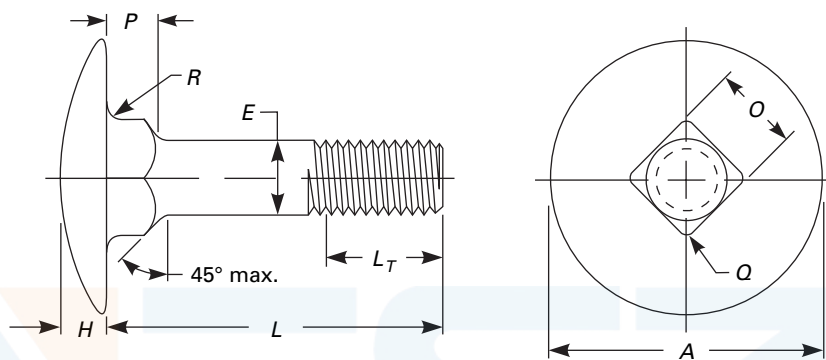

Nominal Size or Basic Bolt Diameter [Note (1)]	Body Diameter, <i>E</i>		Head Diameter, <i>A</i>		Head Height, <i>H</i>		Square Width, <i>O</i>		Square Depth, <i>P</i>		Maximum Corner Radius on Square, <i>Q</i>	Maximum Fillet Radius, <i>R</i> [Note (2)]	
	Max.	Min.	Max.	Min.	Max.	Min.	Max.	Min.	Max.	Min.			
No. 10	0.1900	0.199	0.182	0.656	0.625	0.114	0.094	0.199	0.185	0.125	0.094	0.031	0.031
1/4	0.2500	0.260	0.237	0.844	0.813	0.145	0.125	0.260	0.245	0.156	0.125	0.031	0.031
5/16	0.3125	0.324	0.298	1.031	1.000	0.176	0.156	0.324	0.307	0.187	0.156	0.031	0.031
3/8	0.3750	0.388	0.360	1.219	1.188	0.208	0.188	0.388	0.368	0.219	0.188	0.047	0.031
7/16	0.4375	0.452	0.421	1.406	1.375	0.239	0.219	0.452	0.431	0.250	0.219	0.047	0.031
1/2	0.5000	0.515	0.483	1.594	1.563	0.270	0.250	0.515	0.492	0.281	0.250	0.047	0.031

GENERAL NOTE: For additional requirements, refer to section 2, General Data.

NOTES:

- (1) Where specifying nominal size in decimals, zeros preceding decimal and in the fourth decimal place shall be omitted.
- (2) The minimum radius is one half of the value shown.



**Table 7 Dimensions of Countersunk Bolts and Slotted Countersunk Bolts**

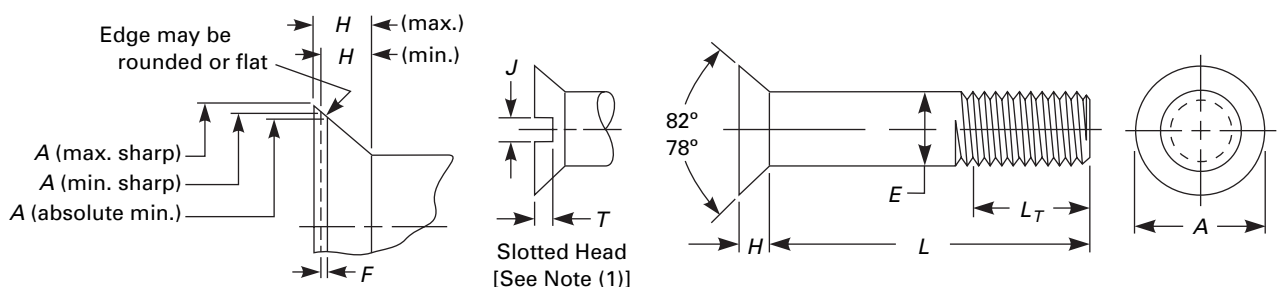

Nominal Size or Basic Bolt Diameter [Note (1)]	Body Diameter, <i>E</i>	Head Diameter, <i>A</i>					Maximum Flat on Min. Dia. Head, <i>F</i> [Note (4)]	Head Height, <i>H</i>		Slot Width, <i>J</i> [Note (5)]		Slot Depth, <i>T</i> [Note (5)]	
		Max.	Min.	Max. Edge Sharp [Note (2)]	Min. Edge Sharp [Note (3)]	Absolute Min. Edge Rounded or Flat		Max.	Min.	Max.	Min.	Max.	Min.
1/4	0.2500	0.260	0.237	0.493	0.477	0.445	0.018	0.150	0.131	0.075	0.064	0.068	0.045
5/16	0.3125	0.324	0.298	0.618	0.598	0.558	0.023	0.189	0.164	0.084	0.072	0.086	0.057
3/8	0.3750	0.388	0.360	0.740	0.715	0.668	0.027	0.225	0.196	0.094	0.081	0.103	0.068
7/16	0.4375	0.452	0.421	0.803	0.778	0.726	0.030	0.226	0.196	0.094	0.081	0.103	0.068
1/2	0.5000	0.515	0.483	0.935	0.905	0.845	0.035	0.269	0.233	0.106	0.091	0.103	0.068
5/8	0.6250	0.642	0.605	1.169	1.132	1.066	0.038	0.336	0.292	0.133	0.116	0.137	0.091
3/4	0.7500	0.768	0.729	1.402	1.357	1.285	0.041	0.403	0.349	0.149	0.131	0.171	0.115
7/8	0.8750	0.895	0.852	1.637	1.584	1.511	0.042	0.470	0.408	0.167	0.147	0.206	0.138
1	1.0000	1.022	0.976	1.869	1.810	1.735	0.043	0.537	0.466	0.188	0.166	0.240	0.162
1 1/8	1.1250	1.149	1.098	2.104	2.037	1.962	0.043	0.604	0.525	0.196	0.178	0.257	0.173
1 1/4	1.2500	1.277	1.223	2.337	2.262	2.187	0.043	0.671	0.582	0.211	0.193	0.291	0.197
1 3/8	1.3750	1.404	1.345	2.571	2.489	2.414	0.043	0.738	0.641	0.226	0.208	0.326	0.220
1 1/2	1.5000	1.531	1.470	2.804	2.715	2.640	0.043	0.805	0.698	0.258	0.240	0.360	0.244

GENERAL NOTE: For additional requirements, refer to section 2, General Data.

NOTES:

- (1) Where specifying nominal size in decimals, zeros preceding decimal and in the fourth decimal place shall be omitted.
- (2) Maximum head height calculated on maximum sharp head diameter, basic bolt diameter, and 78-deg head angle.
- (3) Minimum head height calculated on minimum sharp head diameter, basic bolt diameter, and 82-deg head angle.
- (4) Flat on minimum diameter head calculated on minimum sharp and absolute minimum head diameters and 82-deg head angle.
- (5) Head shall be unslotted, unless otherwise specified. Slot dimensions are same as slotted flat countersunk head cap screws in American National Standard, ANSI B18.6.2.

**Table 8 Dimensions of 114-deg Countersunk Square Neck Bolts**

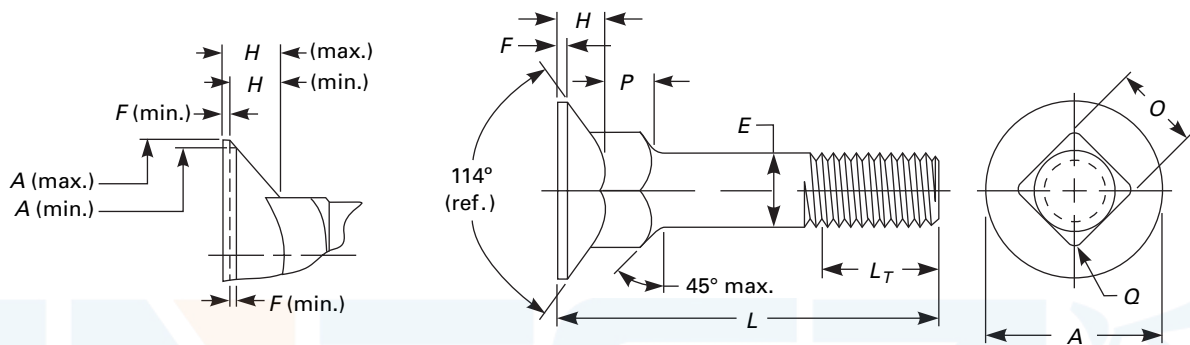

Nominal Size or Basic Bolt Diameter [Note (1)]	Body Diameter, <i>E</i>		Head Diameter, <i>A</i>		Minimum Flat on Head, <i>F</i>	Head Height, <i>H</i>		Square Width, <i>O</i>		Square Depth, <i>P</i>		Maximum Corner Radius on Square, <i>Q</i>	
	Max.	Min.	Max.	Min.		Max.	Min.	Max.	Min.	Max.	Min.		
No. 10	0.1900	0.199	0.182	0.548	0.500	0.015	0.131	0.112	0.199	0.185	0.125	0.094	0.031
1/4	0.2500	0.260	0.237	0.682	0.625	0.018	0.154	0.135	0.260	0.245	0.156	0.125	0.031
5/16	0.3125	0.324	0.298	0.821	0.750	0.023	0.184	0.159	0.324	0.307	0.219	0.188	0.031
3/8	0.3750	0.388	0.360	0.960	0.875	0.027	0.212	0.183	0.388	0.368	0.250	0.219	0.047
7/16	0.4375	0.452	0.421	1.093	1.000	0.030	0.235	0.205	0.452	0.431	0.281	0.250	0.047
1/2	0.5000	0.515	0.483	1.233	1.125	0.035	0.265	0.229	0.515	0.492	0.312	0.281	0.047
5/8	0.6250	0.642	0.605	1.495	1.375	0.038	0.316	0.272	0.642	0.616	0.406	0.375	0.078
3/4	0.7500	0.768	0.729	1.754	1.625	0.041	0.368	0.314	0.768	0.741	0.500	0.469	0.078

GENERAL NOTE: For additional requirements, refer to section 2, General Data.

NOTES:

(1) Where specifying nominal size in decimals, zeros preceding decimal and in the fourth decimal place shall be omitted.

**Table 9 Dimensions of Flat Countersunk Head Elevator Bolts**

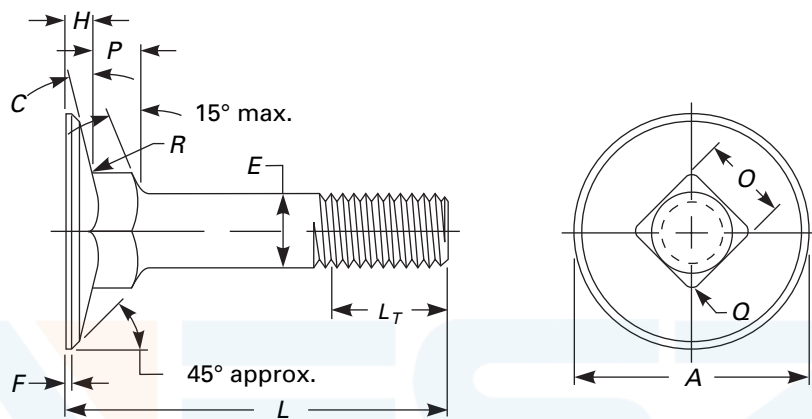

Nominal Size or Basic Bolt Diameter [Note (1)]	Body Diameter, <i>E</i>		Head Diameter, <i>A</i>				Head Angle, <i>C</i> (Ref.)	Max. Flat on Min. Dia. Head, <i>F</i>	Head Height, <i>H</i>		Square Width, <i>O</i>		Square Depth, <i>P</i>		Maximum Corner Radius on Square, <i>Q</i>	Maximum Fillet Radius, <i>R</i> [Note (2)]
	Max.	Min.	Max. Edge Sharp	Min. Edge Sharp	Min. Edge Flat	Max.			Min.	Max.	Min.	Max.	Min.			
No. 10	0.1900	0.199	0.182	0.790	0.750	0.740	9	0.025	0.082	0.062	0.210	0.185	0.125	0.094	0.031	0.031
1/4	0.2500	0.260	0.237	1.008	0.969	0.938	9	0.035	0.098	0.078	0.280	0.245	0.219	0.188	0.031	0.031
5/16	0.3125	0.324	0.298	1.227	1.188	1.157	9	0.035	0.114	0.094	0.342	0.307	0.250	0.219	0.031	0.031
3/8	0.3750	0.388	0.360	1.352	1.312	1.272	11	0.040	0.145	0.125	0.405	0.368	0.250	0.219	0.047	0.031
7/16	0.4375	0.452	0.421	1.477	1.438	1.397	13	0.040	0.176	0.156	0.468	0.431	0.281	0.250	0.047	0.031
1/2	0.5000	0.515	0.483	1.602	1.562	1.522	12	0.040	0.176	0.156	0.530	0.492	0.281	0.250	0.047	0.031

GENERAL NOTE: For additional requirements, refer to section 2, General Data.

NOTES:

- (1) Where specifying nominal size in decimals, zeros preceding decimal and in the fourth decimal place shall be omitted.
- (2) The minimum radius is one half of the value shown.

Table 10 Dimensions of T-Head Bolts

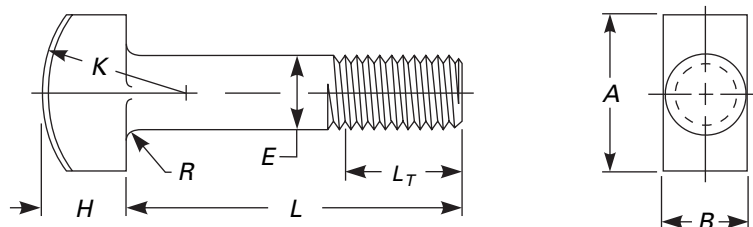

Nominal Size or Basic Bolt Diameter [Note (1)]	Body Diameter, <i>E</i>		Head Length, <i>A</i>		Head Width, <i>B</i>		Head Height, <i>H</i>		Basic Head Radius, <i>K</i>	Maximum Fillet Radius, <i>R</i> [Note (2)]	
	Max.	Min.	Max.	Min.	Max.	Min.	Max.	Min.			
$\frac{1}{4}$	0.2500	0.260	0.237	0.500	0.488	0.280	0.245	0.204	0.172	0.438	0.031
$\frac{5}{16}$	0.3125	0.324	0.298	0.625	0.609	0.342	0.307	0.267	0.233	0.500	0.031
$\frac{3}{8}$	0.3750	0.388	0.360	0.750	0.731	0.405	0.368	0.331	0.295	0.625	0.031
$\frac{7}{16}$	0.4375	0.452	0.421	0.875	0.853	0.468	0.431	0.394	0.356	0.875	0.031
$\frac{1}{2}$	0.5000	0.515	0.483	1.000	0.975	0.530	0.492	0.458	0.418	0.875	0.031
$\frac{5}{8}$	0.6250	0.642	0.605	1.250	1.218	0.675	0.616	0.585	0.541	1.062	0.062
$\frac{3}{4}$	0.7500	0.768	0.729	1.500	1.462	0.800	0.741	0.649	0.601	1.250	0.062
$\frac{7}{8}$	0.8750	0.895	0.852	1.750	1.706	0.938	0.865	0.776	0.724	1.375	0.062
1	1.0000	1.022	0.976	2.000	1.950	1.063	0.990	0.903	0.847	1.500	0.062

GENERAL NOTE: For additional requirements, refer to section 2, General Data.

NOTES:

- (1) Where specifying nominal size in decimals, zeros preceding decimal and in the fourth decimal place shall be omitted.
- (2) The minimum radius is one half of the value shown.

FINESZ 泛微

INTENTIONALLY LEFT BLANK

ASME B18.5-2008

FINESZ 泛微

ISBN-13 : 978-0-7918-3135-9  
ISBN-10 : 0-7918-3135-3



L03208